

The Ultimate Process Valves

TOMOEO TRITEC®

Triple offset and ellipsoidal sealing geometry
 Bi-directional bubble tight shut-off
 Inherently firesafe by design
 Developed Geometry results in:

- Zero seat/Seal friction
- Low torques
- Extended service life
- Continued seal through thermal cycling
- Torque seating

Excellent flow and throttling characteristics covering services from cryogenic to high temperatures.

Excellent control of fugitive emission by virtue of rotary stem movement and advanced packing materials.

- Less than 50ppm on Fugitive Emission Test to cover EPA21

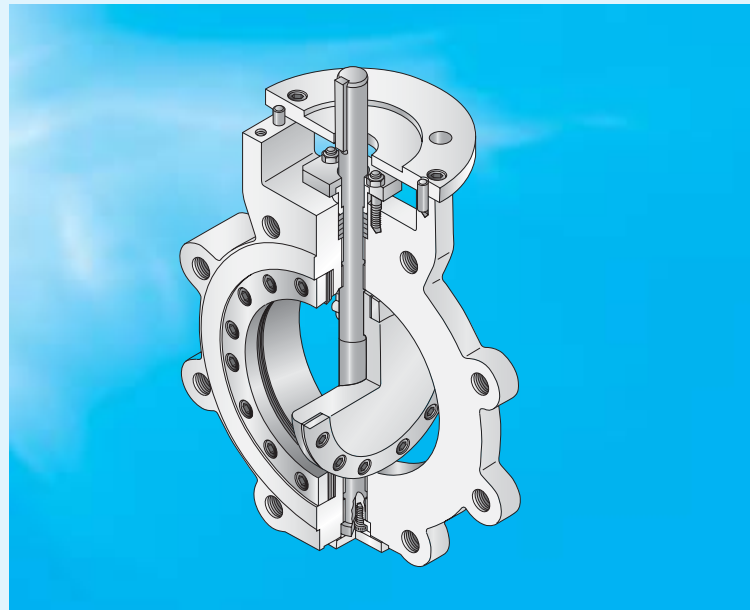

Firesafe requirement meets BS6755 part 2 / API 6FA and API Std 607 4th Edition



Available fully rated to class 2500Lb

Fully rated for end of line duty

Standard materials conform to NACE; all exotic materials also available.

Laminated seat is mounted in the body, removing it from the erosive effects of the flowing media.

Seat is self centering "floating" design.

Both seat and seal are field replaceable without special tools.

Unique elliptical bolting pattern allows foolproof replacement of seat and seal.

Gasket sealing face is completely uninterrupted by fixings.

Suitable for use with spiral wound gaskets and all flange finishes including RTJ.

Antiblowout device on shaft with both internal and external retaining systems according to API Std 609.

ISO mounting flange allows easy fitting and changing of operators.

Operator is bolted and doweled to prevent radial movement and subsequent loss of seating torque.

Body counterbore and seat bolting arranged elliptically to ensure equal support, gasket land and gasket loading all around the elliptical edge of the laminated body seat.

Inboard and outboard thrust mechanisms prevent decentralising of disc, even under high temperature and line pressure.

By eliminating seat-seal friction on unseating, Tritec removes the "Blind Zone" and increases the rangeability or controllable range to the full 90° of movement. The rotation geometry and inboard bearing design reduce the effect of dynamic torque and mechanical noise-vibration, increasing midrange control accuracy. Cavitation and noise reducers are available to complement the Tritec valve under high pressure drop process situations.

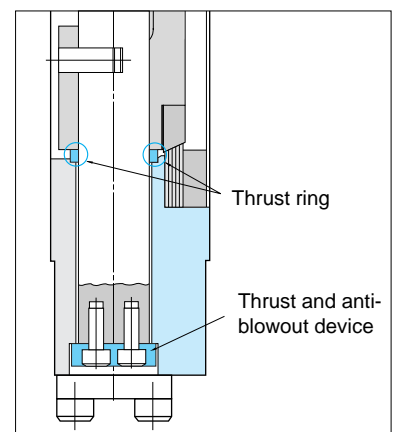
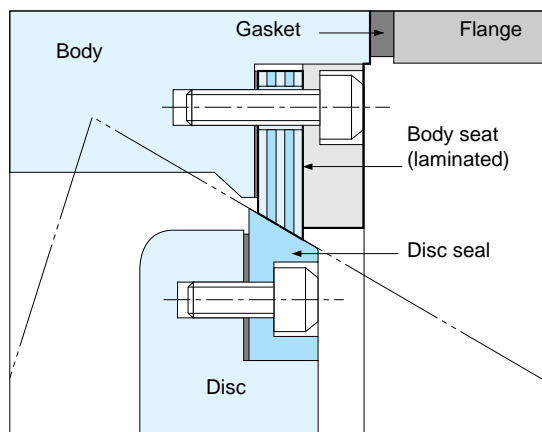

Offset valve-disc/Seat friction

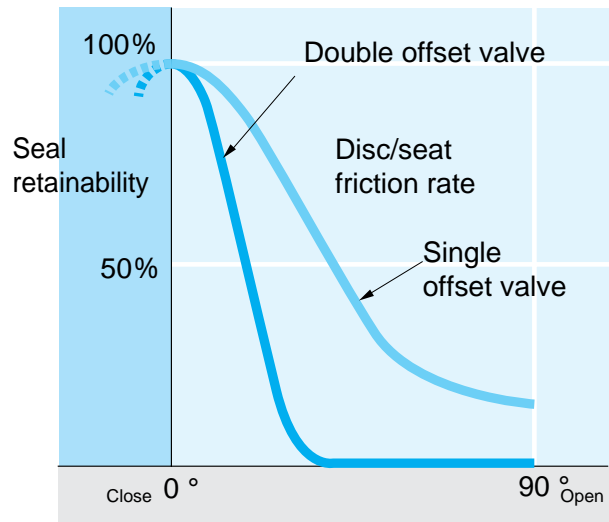
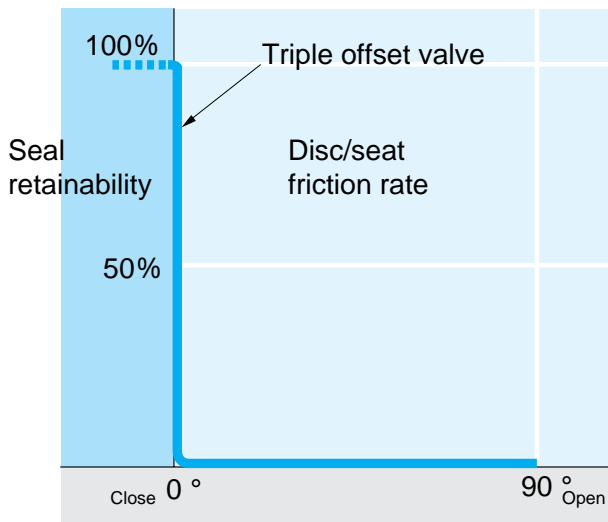

Tracing the evolution of triple offset design

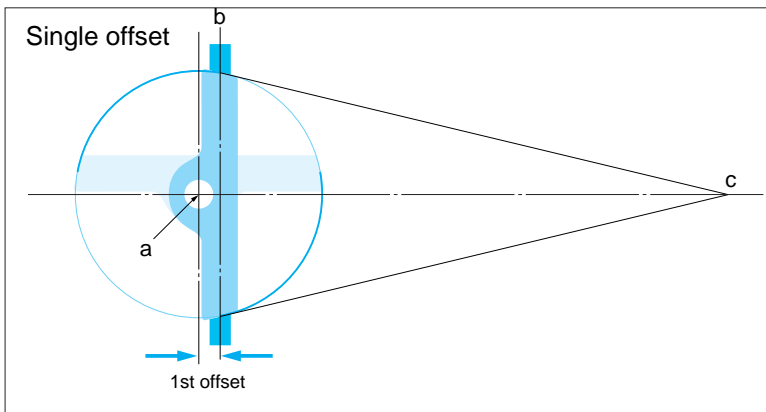

The centre of rotation is moved back from the centreline of the valve disc. The seat and seal are designed conically and on centre. This design relies on a frictional interference seal and so is applicable only to soft seated valves.

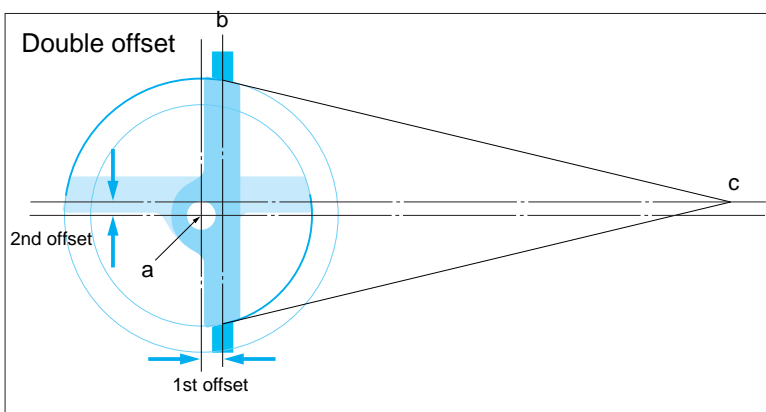

The centre of rotation is moved from the centerline of the valve body. The seat and seal design remains conical and on centre. This design again relies on a frictional interference seal, but the length of rotation over which this friction occurs is reduced, allowing a larger range of process resistant seat materials to be used. However, these materials must be relatively soft or highly elastic to prevent "jamming".

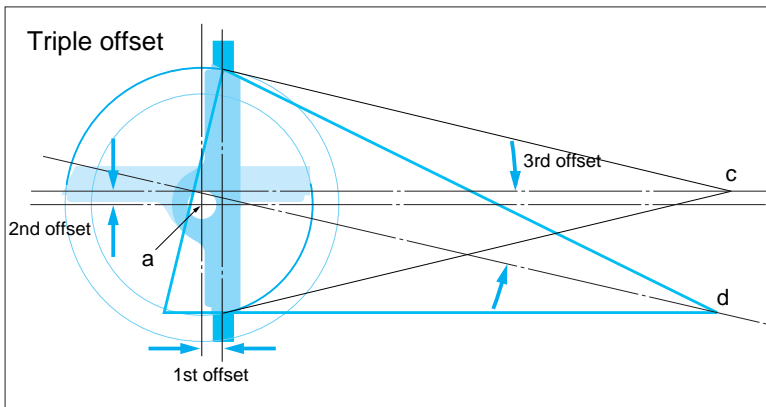

The centreline of the cone is rotated away from the valve centreline resulting in an ellipsoidal profile and providing the third offset. With this geometry, seat seal interference is completely eliminated ensuring long sealing life. The result is a torque seated, process-pressure-aided frictionless seal. The geometry allows the body seat to be used as the closed limit stop, aiding operator adjustment. The triple offset design is ideally suited to metal seated valves providing bubble-tight performance in high temperature, high pressure and firesafe applications.

Butterfly Valves

TRITEC

TT2

334A

302A/303Q

304A/304Q

302Y/304Y

304M^(HLV)

507V/508V

846T/847T/847Q

841T/842T

773Z^(NAV-Z)

700G/704G/705G

731P/732P

732X/731X

700E/700K

704G/722F/720F

LRV

227P

MKT

903C/904C

Standard specifications

Butterfly Valves	Design	API Std 609, BS 5155, ANSI B16.34, ASME SEC *
TRITEC	Valve Sizes ¹	3" (80mm) - 48" (1200mm)
	Pressure Classes	Class 150, 300, 600, 900, 1500, 2500
	Body Styles	Lugged, Wafer flangeless, Double flanged, Butt weld end
TT2	Flange Accommodation ²	ANSI B16.5:DN80 - DN600 ANSI B16.47 Series A&B: DN700 - DN1200
334A	Face to Face ³ Dimensions	Lug and Wafer Type API Std 609 Table 2: DN 80 - DN600 API Std 609 Table 1: DN750, 900, 1050, 1200 ISO 5752 Wafer Short: DN700, 800, 1000
302A/303Q		Double Flanged Type ISO 5752 / BS 5155 Double flange short
304A/304Q		
302Y/304Y	Pressure - ⁴ Temperature Ratings	ASME/ANSI B16.34: for steel ASME/ANSI B16.24: for bronze Working temperature range as standard - 29 degree C (- 20 F) to +538 degree C (1000 F) With selection of suitable materials - 100 degree C (- 148 F) to + 700 degree C (1292 F)
304M(HLV)		
507V/508V	Pressure Tests	Shell test, Seat test: API Std 598 Seat leakage rate API Std 598, ISO 5208 Rate A, ANSI B16.104 (ANSI / FCI 70-2) Class VI
846T/847T/847Q		
841T/842T	Firesafe	Certified firesafe to BS 6755 Part2/API 6FA and API 607
773Z (NAV-Z)	Marking	API Std 609 MSS SP-25
700G/704G/705G	Operators	Manual, Electric, Pneumatic, Hydraulic

1. Please contact a sales office for larger sizes.
2. JIS 10K, 20K, 30K MSS, API, BS, DIN, PN, and ISO also available on request.
3. ISO 5752 Gate Valve Short (Basic series 3) available on request.
4. For Cryogenic range (temperature to - 196 degree C [- 320 F]), please contact a sales office.

Design options

DOUBLE BLOCK & BLEED VALVES

Allows verifiable, maintainable shut-off in critical isolation applications. Fire tested to BS 6755 part 2/API16FA and AP1607 4th edition.



TOP ENTRY VALVES

Allows complete maintainability on valves welded into a line. Available for standard and cryogenic ranges.



CONTROL VALVES

Frictionless seating means increased rangeability, allowing the Tritec valve to perform in both control and isolation applications.

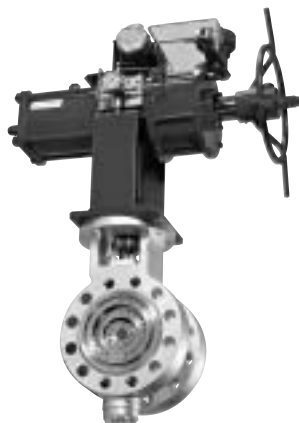

STEAM JACKETED VALVES

Designed to reduce fugitive emission, testing is available for all international standards plus customer specific requirements.



Full-Jacket type

Design options

Gate Valve Face to Face

For the direct replacement of gate valves, all dimensions are exactly as per the standard double flanged valve with the exception of the face to face dimension which is shown below (in accordance with ISO 5752 gate valve short).

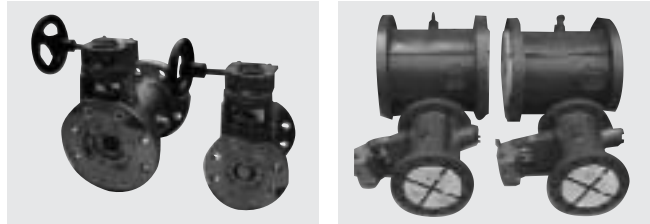

(Unit: mm)

Valve Size		150Lb	300Lb	600Lb	900Lb	1500Lb
mm	inch	Flanged Gate F-F	Flanged Gate F-F	Flanged Gate F-F	Flanged Gate F-F	Flanged Gate F-F
50	2	178	216			
80	3	203	282	356		
100	4	229	305	432	457	
150	6	267	403	559	610	705
200	8	292	419	660	838	832
250	10	330	457	787	838	991
300	12	356	502	838	965	1130
350	14	381	762	889	1029	1257
400	16	406	838	991	1130	1384
450	18	432	914	1092	1219	1537
500	20	457	991	1194	1321	1664
600	24	508	1143	1397	1549	1943

Allows direct replacement of existing gate valves without modification of pipework.

Disc remains within the body face to face in the fully open position to allow removal of the valve from pipework even when the valve is open. Reduction of fugitive emission due to quarter turn rather than linear shaft movement. Reduced operator costs due to quarter turn rather than multi turn/linear.

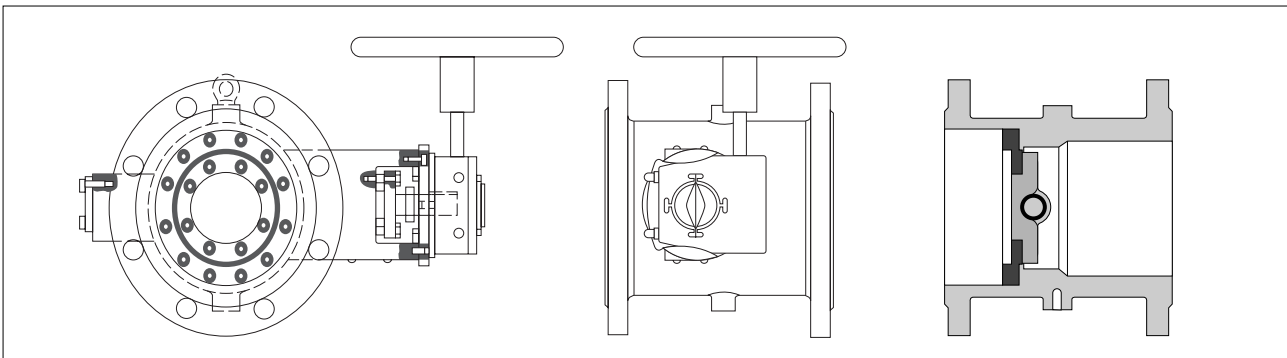

Butterfly Valves

TRITEC

TT2

334A

302A/303Q

304A/304Q

302Y/304Y

304M^(HLV)

507V/508V

846T/847T/847Q

841T/842T

773Z^(NAV-Z)

700G/704G/705G

731P/732P
732X/731X

700E/700K

704G/722F/720F

LRV

227P

MKT

903C/904C

Pressure-temperature ratings

- Butterfly Valves
- TRITEC
- TT2
- 334A
- 302A/303Q
- 304A/304Q
- 302Y/304Y
- 304M(HLV)
- 507V/508V
- 846T/847T/847Q
- 841T/842T
- 773Z(NAV-Z)
- 700G/704G/705G
- 731P/732P
732X/731X
- 700E/700K
- 704G/722F/720F
- LRV
- 227P
- MKT
- 903C/904C

Body	A216	Gr. WCB
Disc	A216	Gr. WCB
Shaft	A564	Type 630

Body	A351	Gr. CF8M
Disc	A351	Gr. CF8M
Shaft	A564	Type 630

Temperature		Working Pressure (MPa)					
(F)	(C)	150	300	600	900	1500	2500
-20	-29	1.96	5.10	10.1	15.2	25.5	42.5
100	38	1.96	5.10	10.1	15.2	25.5	42.5
200	93	1.79	4.65	9.30	13.9	23.2	38.7
300	149	1.59	4.52	9.06	13.5	22.5	37.6
400	204	1.38	4.38	8.75	13.0	21.8	36.3
500	260	1.17	4.14	8.26	12.3	20.6	34.3
600	316	0.965	3.79	7.54	11.2	18.8	31.4
650	343	0.862	3.69	7.40	11.0	18.4	30.8
700	371	0.758	3.69	7.33	11.0	18.3	30.5
750	399	0.655	3.48	6.95	10.4	17.3	28.9
800	427	0.552	2.83	5.68	8.50	14.1	23.6
850	454	0.448	1.86	3.68	5.54	9.23	15.3
900	482	0.345	1.17	2.37	3.54	5.92	9.85
950	510	0.241	0.724	1.41	2.13	3.54	5.92
1000	538	0.138	0.345	0.723	1.06	1.79	2.96

Temperature		Working Pressure (MPa)					
(F)	(C)	150	300	600	900	1500	2500
-20	-29	1.90	4.96	9.92	14.8	24.8	41.3
100	38	1.90	4.96	9.92	14.8	24.8	41.3
200	93	1.62	4.27	8.54	12.8	21.3	35.5
300	149	1.48	3.86	7.71	11.5	19.2	32.1
400	204	1.34	3.55	7.06	10.6	17.7	29.4
500	260	1.17	3.31	6.57	9.88	16.4	27.4
600	316	0.965	3.10	6.20	9.33	15.5	25.9
650	343	0.862	3.07	6.13	9.16	15.2	25.4
700	371	0.758	2.96	5.99	8.99	14.9	24.9
750	399	0.655	2.93	5.89	8.81	14.7	24.5
800	427	0.552	2.90	5.82	8.71	14.5	24.2
850	454	0.448	2.90	5.75	8.64	14.4	23.9
900	482	0.345	2.86	5.71	8.57	14.2	23.8
950	510	0.241	2.65	5.33	7.99	13.2	22.1
1000	538	0.138	2.41	4.82	7.23	12.0	20.0

Notes 1. Permissible, but not recommended for prolonged use above 800 F(427 degree C).
Please contact a sales office for temperatures outside of standard temperature range as detailed in the above table.

Pressure-Temperature Ratings (ANSI B 16.34)

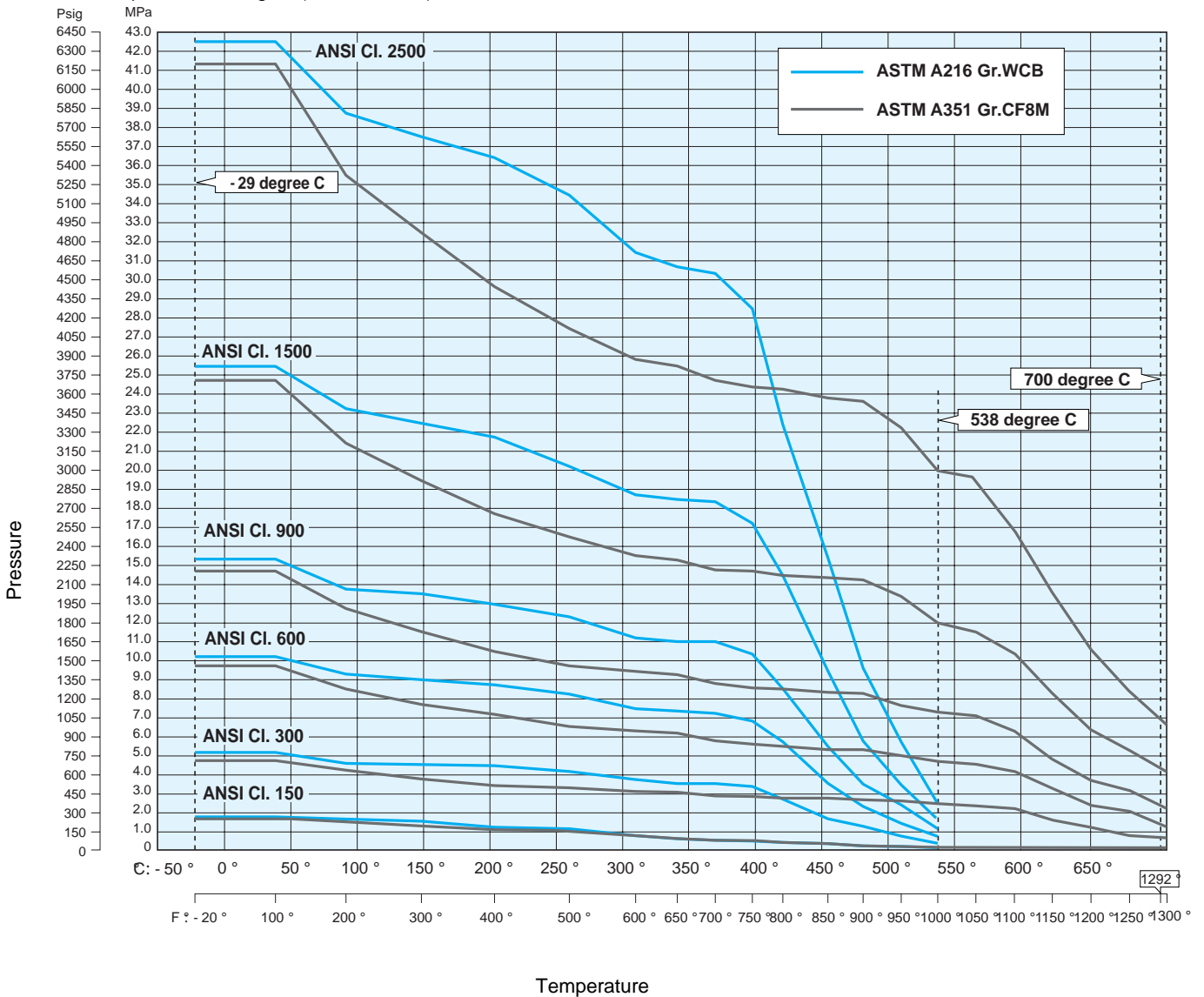

Comparison of allowable seat leakage rates by standard

Gas Test

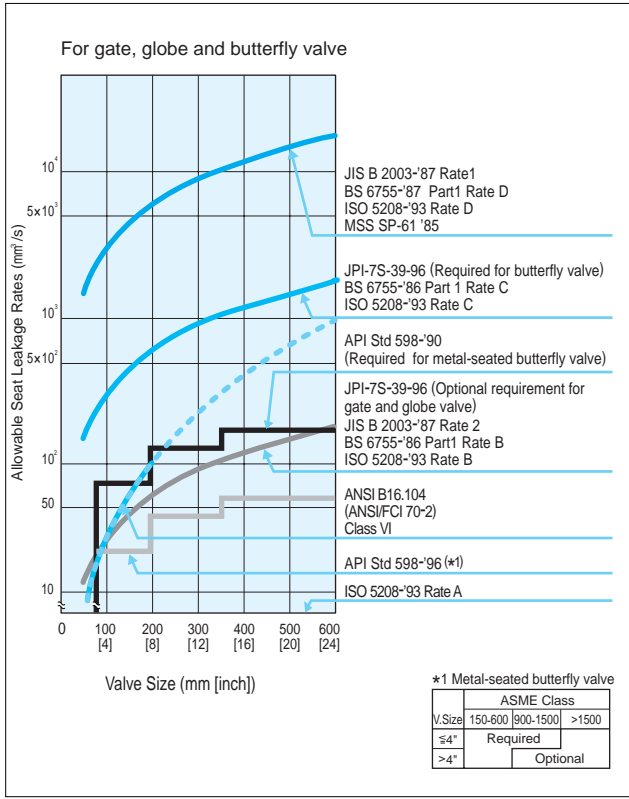

Hydrostatic Test

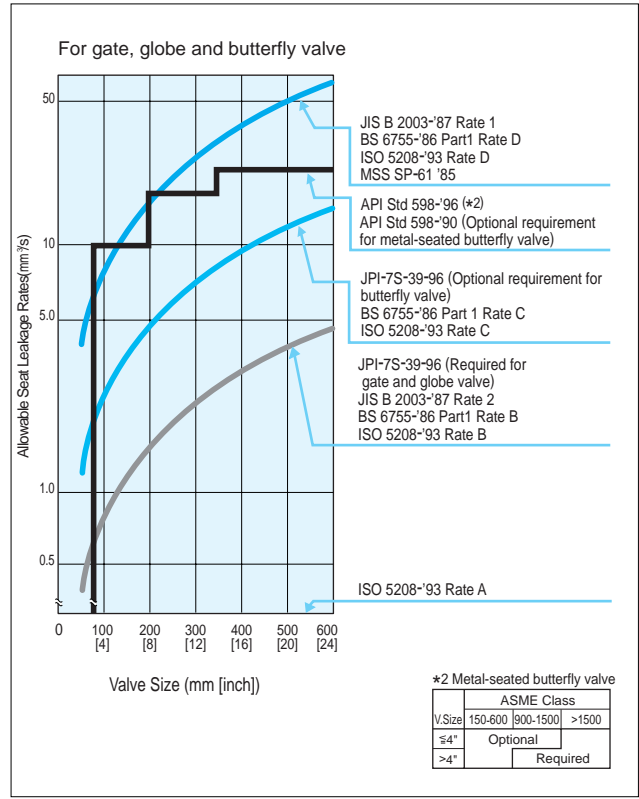

Allowable seat leakage rates by standard

Gas Test

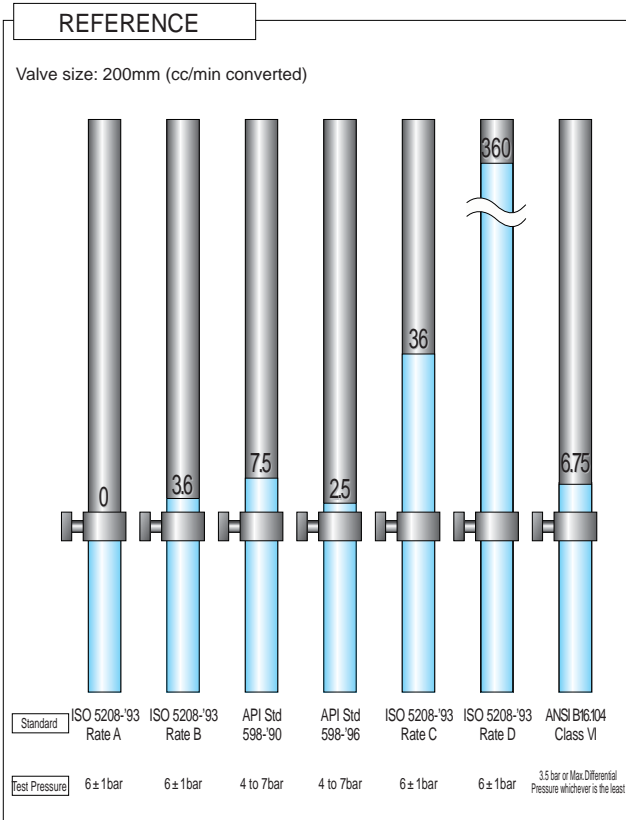

Hydrostatic Test

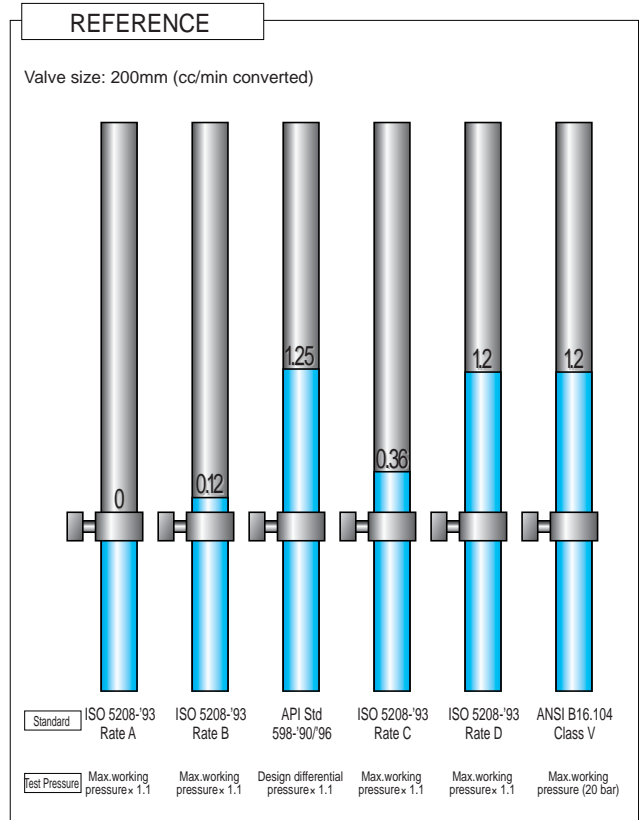

Butterfly Valves

TRITEC

TT2

334A

302A/303Q

304A/304Q

302Y/304Y

304M (HLV)

507V/508V

846T/847T/847Q

841T/842T

773Z (NAV-Z)

700G/704G/705G

731P/732P

732X/731X

700E/700K

704G/722F/720F

LRV

227P

MKT

903C/904C

Operating and maintenance instructions

Butterfly Valves

TRITEC

TT2

334A

302A/303Q

304A/304Q

302Y/304Y

304M(HLV)

507V/508V

846T/847T/847Q

841T/842T

773Z(NAV-Z)

700G/704G/705G

731P/732P
732X/731X

700E/700K

704G/722F/720F

LRV

227P

MKT

903C/904C

No	Description	Q'ty
1	Body	1
2	Disc	1
3	Body seat	1
4	Body seat retaining ring	1
5	Body seat gasket	1
6	Disc seal	1
7	Disc seal gasket	1
8	Shaft	1
9	Shaft pin	2 - 4
10	Bearing	4
11	Thrust ring	1
12	Thrust pad	1
13	End cover	1
14	End cover gasket	1
15	Gland plate	1
16	Gland plate spigot	1

No	Description	Q'ty
17	Mounting plate	1
18	Dowel pin	2 - 4
19	Nameplate	1 - 2
22	Disc seal screw	1set
23	Thrust pad screw	2 - 3
24	Body seat screw	1set
25	Mounting plate screw	4 - 6
26	End cover screw	4
27	Gland stud	2
29	Gland nut	2
33	Gland packing	3
34	Gland packing	2
35	Key	1
37	Anti-blowout collar	1
38	Anti-blowout set screw	1 - 2

: Recommended spare parts

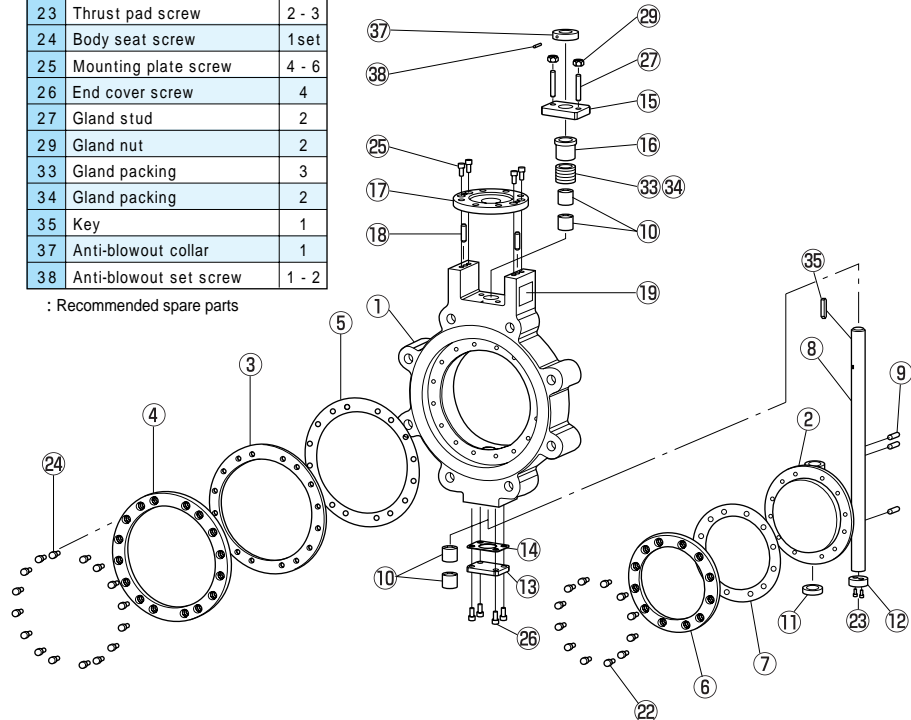

INTRODUCTION

These instructions provide general information on the operation, installation and maintenance of the Tritec triple offset valve. Tritec valves have been designed and manufactured to operate in an aggressive environment under extremes of temperature and pressure for long periods and with minimal maintenance.

INSTRUCTIONS

PACKING

- All valves should be shipped with protective covers attached to the flange faces to protect the gasket sealing surfaces and internal trim.
- The valve disc is cracked off the seat in the almost closed position.
- The Tritec nameplate shown in the picture contains information such as size, pressure class, materials and the unique serial number.

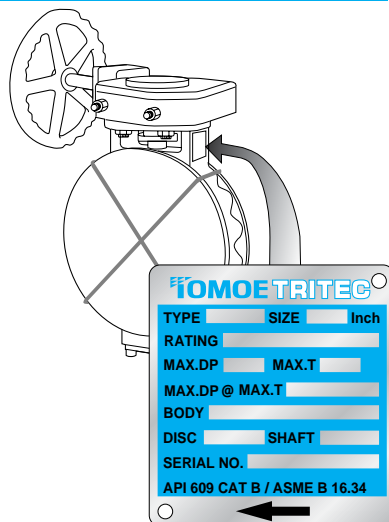

SPARE PARTS

- When ordering spare parts or discussing matters concerning this valve with a sales office, you must provide the unique serial number of the valve found on the stainless steel nameplate attached to the valve body adjacent to the operator.

TRANSPORTATION

- Use crates or packing cases for ocean transportation.
- For overland transportation, a covered vehicle is recommended with protective sheets covering the valves.

STORAGE

- Store the valves indoors in a cool temperature between -10 degrees and +60 degrees C with humidity at 70% or less.
- Do not remove the protective covers until ready to install valves.
- Machined ferrous surfaces are protected with an approved rust preventative. For long periods of storage, apply the rust preventative once a year to the unpainted surfaces.
- When storing valves unpacked, take care to protect valves and actuators from excessive loads. Do not stack unpacked valves.
- If the valve is for clean gas duty and is being supplied degreased a label will be attached stating this and the valve will be sealed in a polythene covering. It is suggested that the valve be kept packed until it is installed in the pipeline.

UNPACKING

- Unpack valves just before installation.

INSTALLATION

- The valve is designed to seal against bidirectional flow and can therefore be installed with flow in either direction. However, enhanced sealing life will be obtained with upstream flow against the shaft side of the disc. This preferred flow direction is shown on the nameplate attached to the valve body adjacent to the operator and also on the GA drawing. The valve may be installed in the pipeline with the valve shaft in a horizontal, vertical or intermediate position.
- Prior to installation, the pipeline must be cleaned from dirt and welding residues to avoid damage to the valve during operation.
- Ensure that the valve is closed prior to installation to avoid the risk of damage to the sealing surfaces.

Operating and maintenance instructions

- ④ The valve must be lifted by the eyebolt or lifting eyes provided with the valve.
- ⑤ The valve must not be lifted by the operator or handwheel.
- ⑥ The valve must not be used for pipework alignment.
- ⑦ The Lugged or Double flanged type valve is suitable for dead end service, ie. end of line duty, in either direction (in case of the valve specified for both directions) to the full rating pressure of the piping system.

MAINTENANCE

Tomoe Tritec triple offset valves are designed for minimum maintenance, however, it is recommended that the valve be cycled several times from fully open to fully closed every 3 months. To carry out maintenance as detailed below, no special tools are required, but it should be noted that a torque wrench covering the torque range required will be needed. Before carrying out any of the maintenance detailed below, please ensure that a copy of the relevant GA drawing is available to facilitate identification and location of the component parts.

Adjustment / Replacement of Gland Packing

The Tomoe Tritec triple offset valve is supplied with a graphite adjustable gland packing which has been packed and adjusted for immediate use. However during service, leakage may occur and it may be necessary to tighten the Gland nut ⑳. This can be done with the operator on the valve. Do not overtighten the nuts, however, as this may cause damage to the valve and may lead to increased operating torque. If leakage persists then the Gland packings ㉓ and ㉔ must be replaced and the procedure below followed:

Disassembly

1. Remove the valve operator.
2. Remove the Mounting plate ⑰.
3. Remove the Key ㉕ on the Shaft ⑧.
4. Remove the Anti-blowout set screws ㉖ and slide the Anti-blowout collar ㉗ off from the end of the Shaft ⑧.
5. Remove the Gland plate ⑮ and Gland plate spigot ⑯ by undoing the Gland nuts ㉑ and sliding both parts off from the end of the Shaft.
6. Extract the Gland packings ㉓ and ㉔ using a scribe. Do not reuse the gland packings.

Assembly

1. Clean the gland packing hole of all dust and other foreign debris.
2. Insert a new packing set (standard: both the braided outer rings and the plain inner rings) into the packing hole, taking care when sliding the rings over the shaft not to damage them on the keyway.
3. Replace the Gland plate ⑮ and Gland plate spigot ⑯, and tighten the Gland nuts ㉑ to the torque specified on the GA drawing. Do not overtighten as this will increase valve operating torques and may lead to damage to the valve.
4. Replace the Anti-blowout collar ㉗ and tighten the Anti-blowout set screws ㉖.
5. Replace the Mounting plate ⑰ on the top of the Body ① ensuring that the Dowel pins ⑱ are refitted and that the Mounting plate screws ㉒ are secured to the torque specified on the GA drawing.
6. Replace the valve operator ensuring that the Dowel pins ⑱ are refitted (if supplied) and tighten the fixings. Secure the Key ㉕ on the Shaft ⑧.

Replacement of the Laminated Body Seat and/or Disc Seal

The Tomoe Tritec triple offset valve incorporates several innovative features which ensure long operating life and easy maintenance. The laminated Body seat ③ and the Disc seal ⑥ are readily field replaceable with no special tools, meaning that both parts of the sealing mechanism can be replaced without sending the valve back to the factory. The Body seat ③ and Disc seal ⑥ are accurately machined on special fixtures so that they are not matched pairs and

can be replaced either independently or as a pair.

Due to the triple offset geometry, the Body seat ③ and Disc seal ⑥ must be fitted into the valve with the correct radial alignment both relative to each other and relative to the shaft.

To facilitate this alignment, the Body seat ③, Body seat retaining ring ④, Disc seal ⑥, Body ① and Disc ② all have an alignment arrow stamped on the component at 9 o'clock when viewed from the disc side. These components must be assembled with the alignment arrows in the same position. To aid initial alignment of these components and also correct the alignment of the Body seat gasket ⑤ and the Disc seal gasket ⑦, the drillings are of an irregular spacing and can only be aligned in one orientation. It is essential to tighten the Body seat screws ㉔ and Disc seal screws ㉒ to the torque given on the GA drawing.

Disassembly

1. The Disc ② should be in an approximately 20 degrees opened position.
2. Remove the Body seat screws ㉔.
3. Remove the Body seat retaining ring ④, Body seat ③ and Body seat gasket ⑤.

If the Disc seal ⑥ is to be replaced as a result of visual inspection,

- At this point, return Disc ② to the fully closed position.
- Remove Disc seal screws ㉒ and then remove Disc seal ⑥ and Disc seal gasket ⑦.
- This work should be done with Disc ② in the upward position.

Assembly

1. Ensure that Disc ② is in a central float position by pushing Disc ② as far as possible toward the operator.

If Disc seal ⑥ was replaced as a result of visual inspection,

- Ensure that the gasket sealing surface on Disc ② is clean and free from gasket debris, etc.
- Replacement procedure for Disc seal ⑥ is the reverse of the above but it should be used with a new Disc seal gasket ⑦.
- This assembly should be done with Disc ② in the upward position.
- The correct radial alignment of these components is achieved using the alignment arrows.
- Tighten Disc seal screws ㉒ to the torque given on the GA drawing.

2. Ensure that the gasket sealing surface in the Body ① is clean and free from gasket debris, etc.
3. Replacement procedure for Body seat ③ is the reverse of the disassembly described above, but it should be used with a new Body seat gasket ⑤.
4. The valve should be in the Disc ② upward position and in an approximately 20 degrees opened position.
5. Replace the new Body seat gasket ⑤ with correct alignment. Apply a light smear of graphite grease to the top side of Body seat ③ and the underside of Seat retaining ring ④ and then replace these components.
6. To ensure correct positioning of Body seat ③, only Body seat screws ㉔ should be lightly tightened, which will provide a slight tension through the screws. Close Disc ② lightly and then open it again.
7. Tighten Body seat screws ㉔ to about 50% of the torque specified on the GA drawing. At this stage close the Disc using the operator so that the valve is fully closed and Disc ② seal ⑥ is firmly located against Body seat ③.
8. Ensure that the gap between Disc ② and Thrust ring ① is within the tolerance specified on the GA drawing.

[Note] If the gap is smaller than the correct tolerance, Disc ② might move toward End cover ⑬. In this case please contact a sales office for the countermeasure.

9. Tighten Body seat screws ㉔ to the correct torque as given on the GA drawing.

Butterfly Valves

TRITEC

TT2

334A

302A/303Q

304A/304Q

302Y/304Y

304M(HLV)

507V/508V

846T/847T/847Q

841T/842T

773Z(NAV-Z)

700G/704G/705G

731P/732P
732X/731X

700E/700K

704G/722F/720F

LRV

227P

MKT

903C/904C