

PMK-SRM

The PMK-SRM is an electrical spring return type actuator that does not require a power supply unit and protects your piping from damage during emergencies. It serves as a safety countermeasure for various fluid lines, from water, sewage and steam lines, to chemical and powder lines.



Features

Reliable motorized spring return system

Does not require a power supply unit

On and off operations, proportional control, and emergency shut-off all in one device

PMK-SRM Type Standard Specifications

Type	PMK-005SRM		PMK-010SRM		PMK-030SRM		PMK-080SRM		
Output torque	49N•m		88N•m		294N•m		784N•m		
Motor power source	AC100V 50/60Hz	AC200V 50/60Hz	AC100V 50/60Hz	AC200V 50/60Hz	AC100V 50/60Hz	AC200V 50/60Hz	AC100V 50/60Hz	AC200V 50/60Hz	
Power consumption (VA)	Rated	35	48	46	48	130	120	200	200
	Startup	70	110	100	110	290	280	300	300
Travel time (50/60Hz) (sec)	Spring winding	55/43		55/46		61/49		60/50	
	Opening and closing	40/33		46/38		49/41		55/46	
	Emergency shut-off (return)	Max. 2		Max. 3		Max. 10		Max. 20	
Current value (A)	Spring winding	0.35	0.24	0.46	0.24	1.3	0.6	2.0	1.0
	Rated	0.09	0.04	0.09	0.04	0.12	0.06	0.24	0.12
Time rating	30 minutes								
No. of poles	4								
Insulation	Class E								
Motor protection	Thermal protector								
Space heater	Option								
Position limit switch	One each for fully open and fully closed (contact capacity: AC250V, 10A)								
Torque limit switch	None								
Mechanical limit stop	End of travel positioning bolt built-in								
Conduit connections	G3/4 at one port								
Enclosure	JIS C 0920 (IP54), Class 4, dust and water-jet proof type								
Manual operation	None								
Ambient temperature	- 10 to 50 degrees C								
Coating	Silver hammer net (Munsell N7)								
Options	① Potentiometer (135 , 500)								
	② Electro-electro Positioner (4 to 20 mA DC I/O)								

Note: A sun cover is required if you will be using this product outdoors. For details please consult us.

Actuator
New ELMY
New MCOM ELMY II
PMK-SRM
SRJ
LTKD
T-DYNAMO
TGA
TG-S
3C
Diaphragm
Hydraulic type
Manual type

PMK-SRM Dimensions

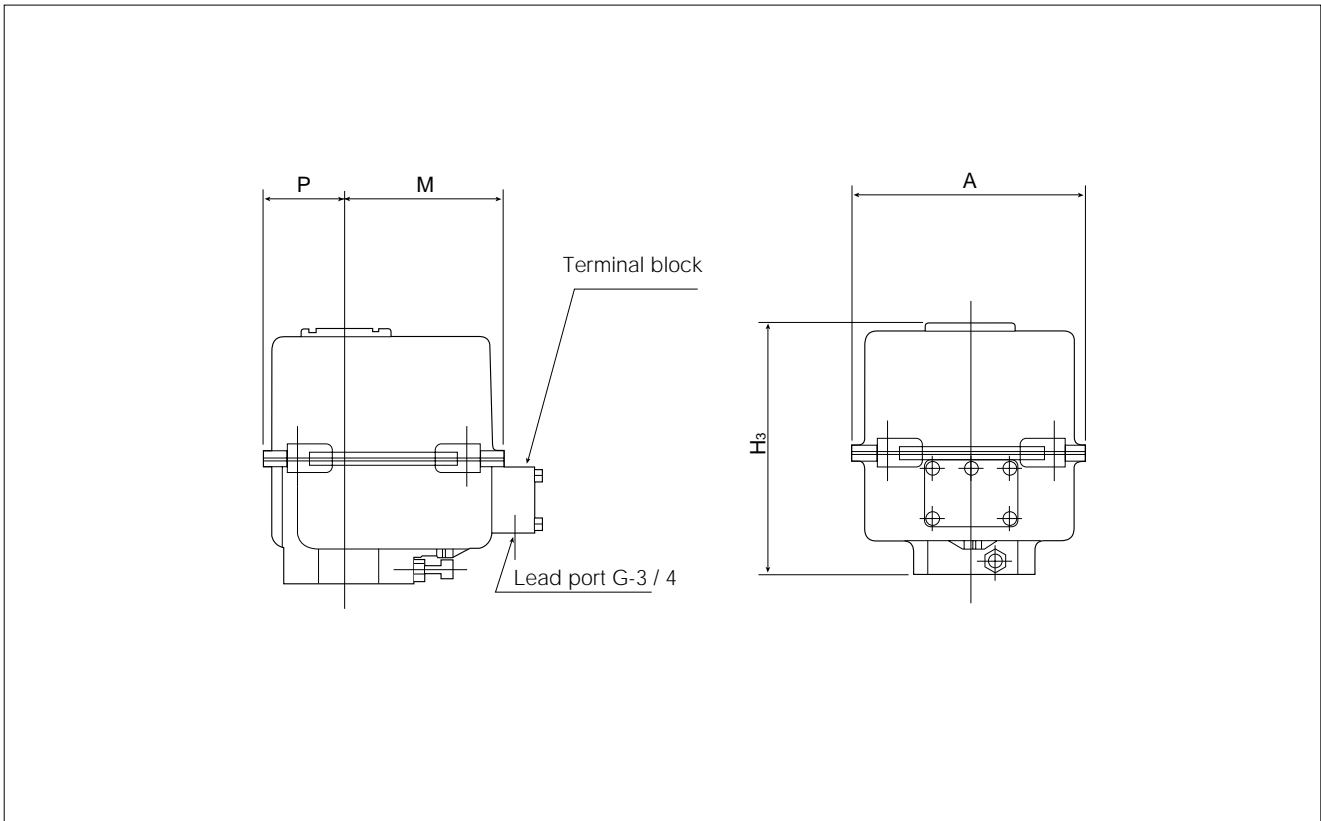

PMK-SRM Dimensions / Weight

Type	Dimension(mm)				Approx. weight (kg)
	A	M	P	H ₃	
PMK-005SRM	205	171	70.5	221	10
PMK-010SRM	205	171	70.5	284	11
PMK-030SRM	240	206	85	457	35
PMK-080SRM	300	210	150	364	40

Actuator

New ELMY

New MICOM ELMY II

PMK-SRM

SRJ

LTKD

T-DYNAMO

TGA

TG-S

3C

Diaphragm

Hydraulic type

Manual type

PMK-SRM

PMK-SRM Operation Circuit

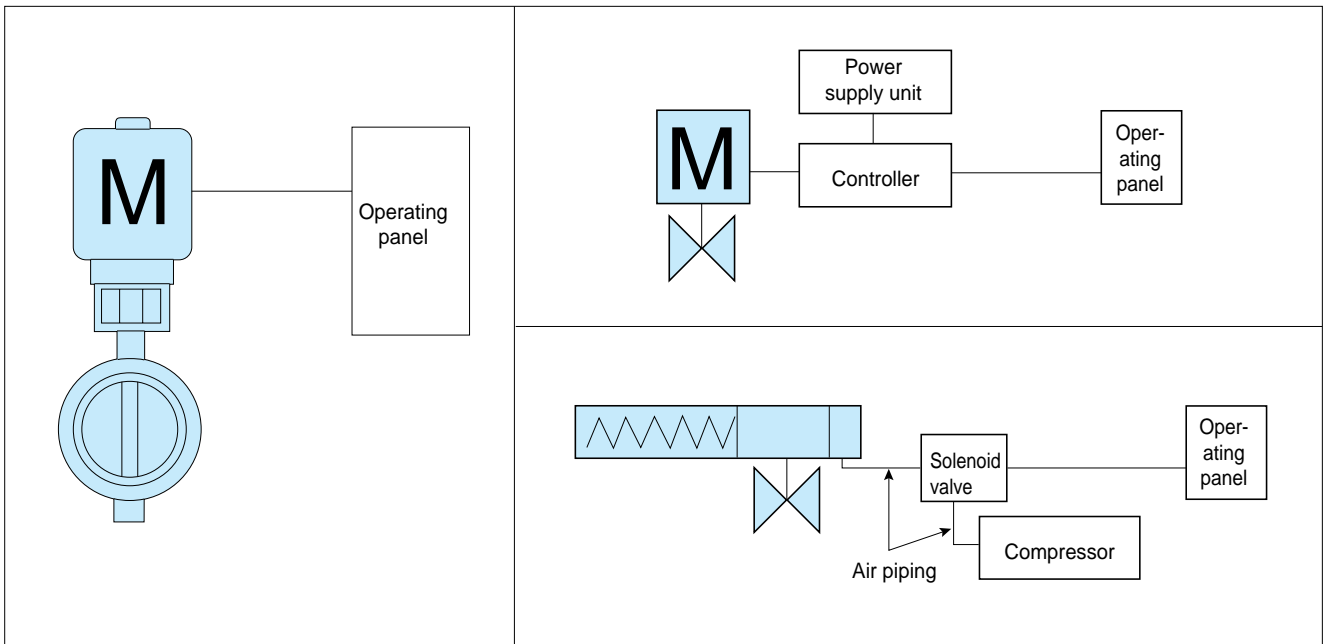

PMK-SRM Circuit and Explanation of Operation

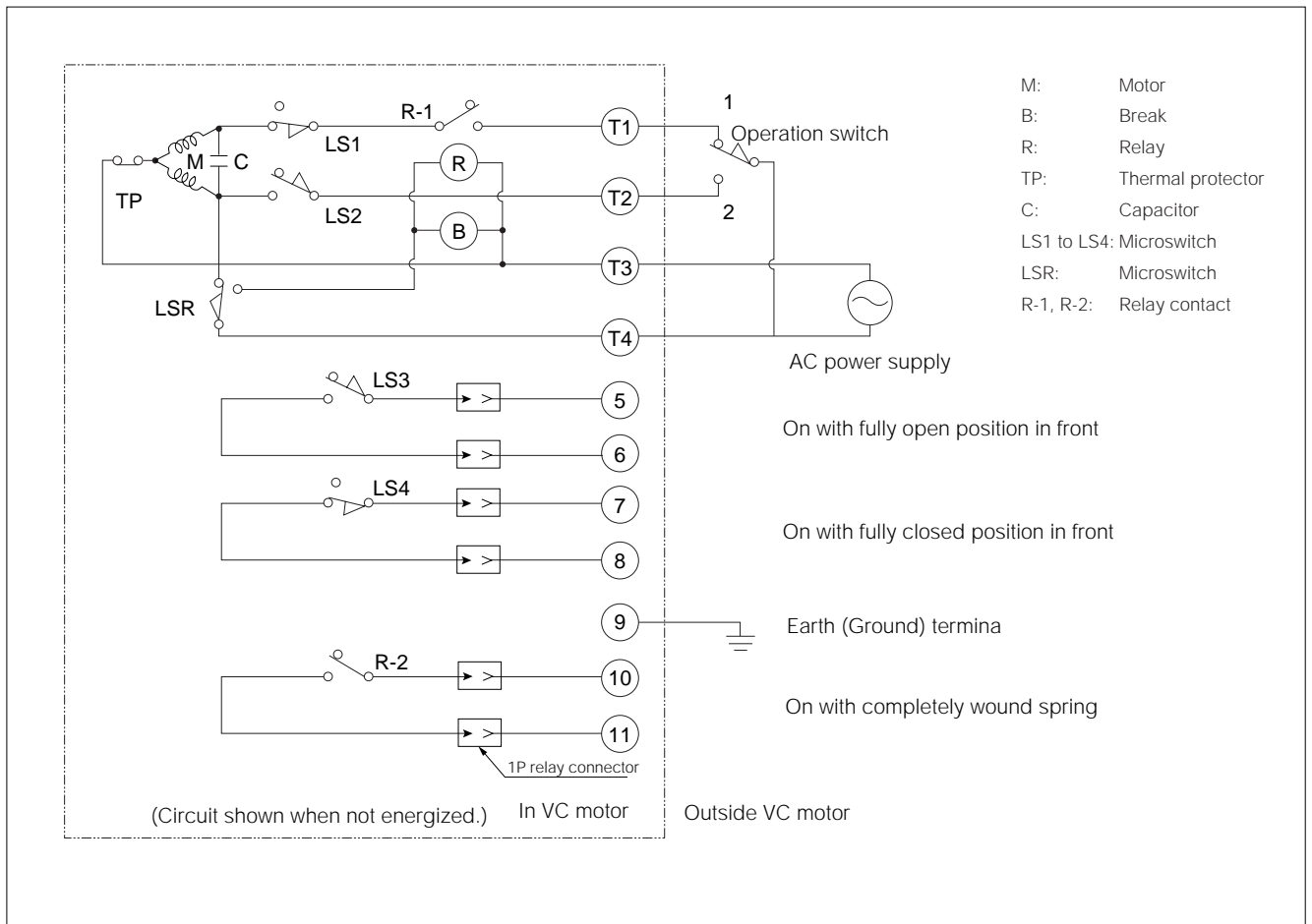

Actuator
New ELMY
New MICON ELMY II
PMK-SRM
SRJ
LTKD
T-DYNAMO
TGA
TG-S
3C
Diaphragm
Hydraulic type
Manual type