

# New MICOM ELMY II

The New MICOM ELMY II offers highly accurate controllability, and its various functions are easily set via communication with a personal computer.



## Controller features

Flow characteristics can be set at work site with PC.

High reliability

Adjustable operating speed

Multiple functions

Compact

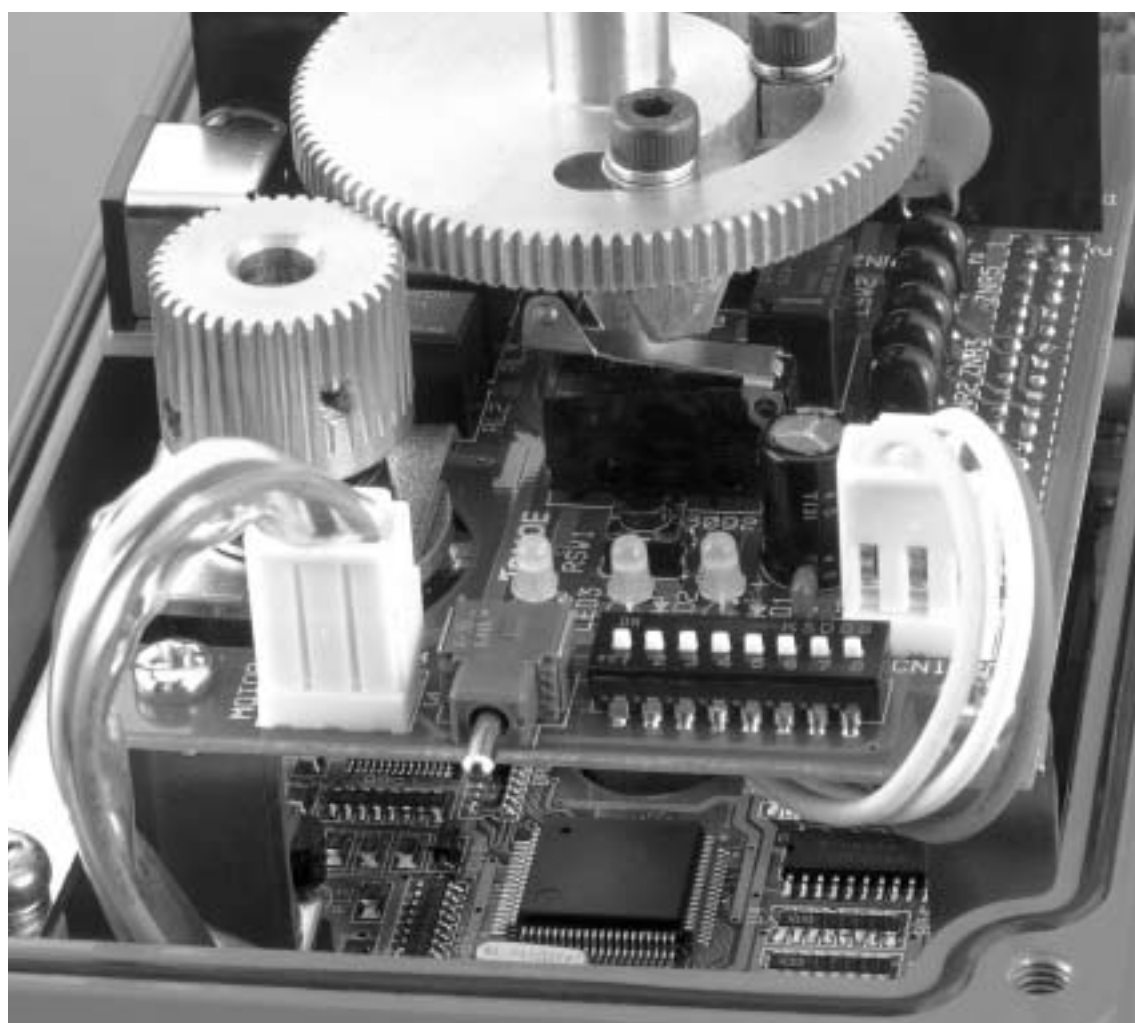

### Actuator

New ELMY

New MICOM ELMY II

PMK-SRM

SRJ

LTKD

T-DYNAMO

TGA

TG-S

3C

Diaphragm

Hydraulic type

Manual type

New MICOM ELMY II Specifications (Controller)	
<b>Model</b>	New MICOM ELMY II
<b>Input signal</b>	4 to 20mA DC (input resistance 250 ohm) 1 to 5V DC
<b>Non-voltage contact input</b>	Open / close signal (a contact)
<b>Output signal</b>	4 to 20mA DC (load resistance 300 )
<b>Non-voltage contact output</b>	Open / close contact signal (Capacity AC220V-0.3A, DC24V-1A) Alarm output for hunching and thermal rising (Capacity AC220V-0.3A, DC24V-1A) Power off output for excessive torque and thermal rising (Capacity AC220V-0.3A, DC24V-1A)
<b>Operation frequency rate</b>	50% ED or less
<b>Inching operation</b>	60 times / min. or less
<b>Positioning accuracy</b>	± 1% (For operation range of 90 degrees C, input signal amplitude of 16mA during linear operation.)
<b>Resolution</b>	1 / 200 (For operation range of 90 degrees C, input signal amplitude of 16mA during linear operation.)
<b>Flow characteristic variation</b>	Cv linear settings (concentric and eccentric type are built into controller.) Disc angle linear settings Flow linear settings
<b>Input signal mode</b>	Direct, reverse
<b>Input signal failure mode</b>	Stop, open, close or optional position
<b>Output signal mode</b>	Direct, reverse
<b>Zero-span adjustment range</b>	-5 to 95 degrees C
<b>Hysteresis adjustment range</b>	0.5 to 4.0% at full span
<b>Operation speed control</b>	Range and operation speed can be adjusted.
<b>Protection function</b>	Limit switch at full open and close Mechanical stopper

Resolution is set at 1/100 at the time of shipment. If any other resolution is required, please contact us.

New MICOM ELMY II Specifications (Actuator)						
Type	Type 0	Type 1	Type 2	Type 2.5	Type 3	Type 4
<b>Output torque( N·m )</b>	70	98	196	333	981	2000
<b>Power source( V )</b>	AC100, 200, 120, 220 50/60Hz					
<b>Motor capacity( W )</b>	8W	20W	30W		90W	
<b>Operating range</b>	0 to 90 degrees C					
<b>Travel time( 50 / 60Hz ) ( sec )</b>	25/20 sec(0 to 90 degrees C)			37/30 sec (0 to 90 degrees C)	55/50 sec (0 to 90 degrees C)	125/105 sec (0 to 90 degrees C)
<b>Insulation</b>	Class E					
<b>Enclosure</b>	IP65					
<b>Protect function</b>	Built in mechanical thermal protector stopper at full open and close side					
<b>Conduit connections</b>	G1/2( PF1/2 )2 port					
<b>Manual operation</b>	Detachable handle	Declutchable handwheel				
<b>Motor protection</b>	Built-in thermal protector					
<b>Mechanical stopper</b>	End of travel positioning bolt					
<b>Environmental temperature during operation</b>	- 10 to 50 degrees C					
<b>Environmental temperature during storage</b>	- 30 to 80 degrees C					
<b>Paint finish</b>	Epoxy-melanin baked with Munsell 2.5BG 6/12					

Actuator
New ELMY
New MICOM ELMY II
PMK-SRM
SRJ
LTKD
T-DYNAMO
TGA
TG-S
3C
Diaphragm
Hydraulic type
Manual type

# TOMOE's software is compatible with Windows® 98, 2000 and ME.

## Setting functions

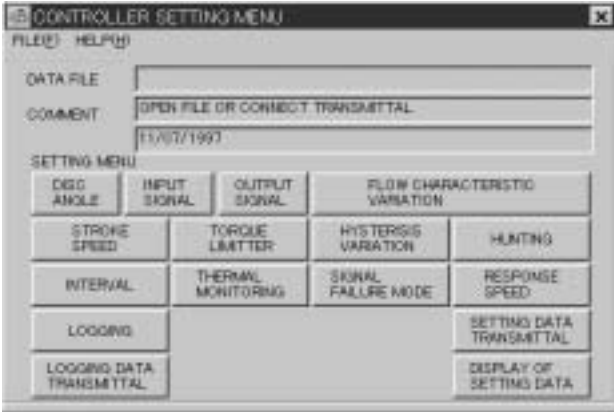

Various functions are easily set with a personal computer at the job site. Factory setting is also available for specific customer requests. TOMOE's software and instruction manual are available for purchase.

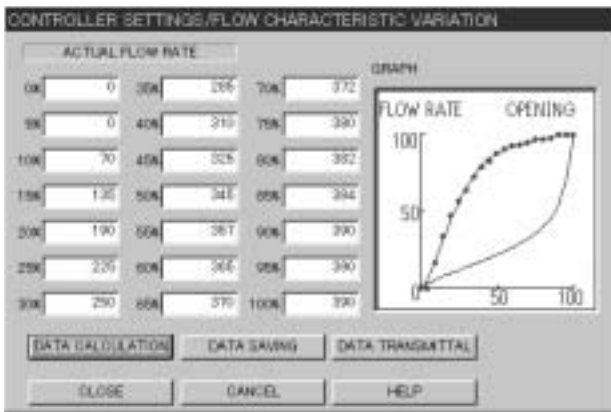

### Variable flow characteristics

Based on the actual flow rate at each opening degree, the relationship between valve movement and input signal can be varied. Linear characteristics can be achieved as follows:

Linear characteristics can be achieved as follows:

- Input signal: 20%
- Opening angle: 20%
- Actual flow rate: 50%

After setting;

- Input signal: 20%
- Opening angle: 8%
- Actual flow rate: 20%

Low rate data can be set at each 5% of opening. If flow rates at certain angles are not known, the program will automatically compensate for this to achieve the necessary data. \*\*\*\*\*

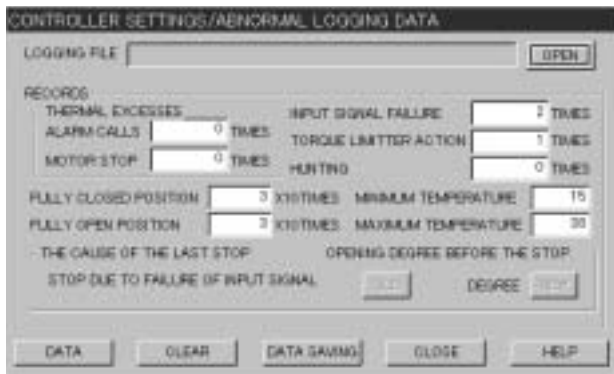

### Abnormal data logging

The unit monitors actual operating conditions.

Using this function, the operator can predict the cause of potential problems.

The number of alarm calls due to thermal excesses in the actuator, the action of the torque limiter and the frequency of hunting during operation, are all recorded.

Opening and closing stroke time can also be recorded. This enables the operator to plan maintenance routines and schedules.

Make good use of this function to improve accuracy, valve sizing, and opening speed characteristics.

Actuator
New ELMY
New MICOM ELMY II
PMK-SRM
SRJ
LTKD
T-DYNAMO
TGA
TG-S
3C
Diaphragm
Hydraulic type
Manual type



**New MICOM ELMY II Dimensions diagram**

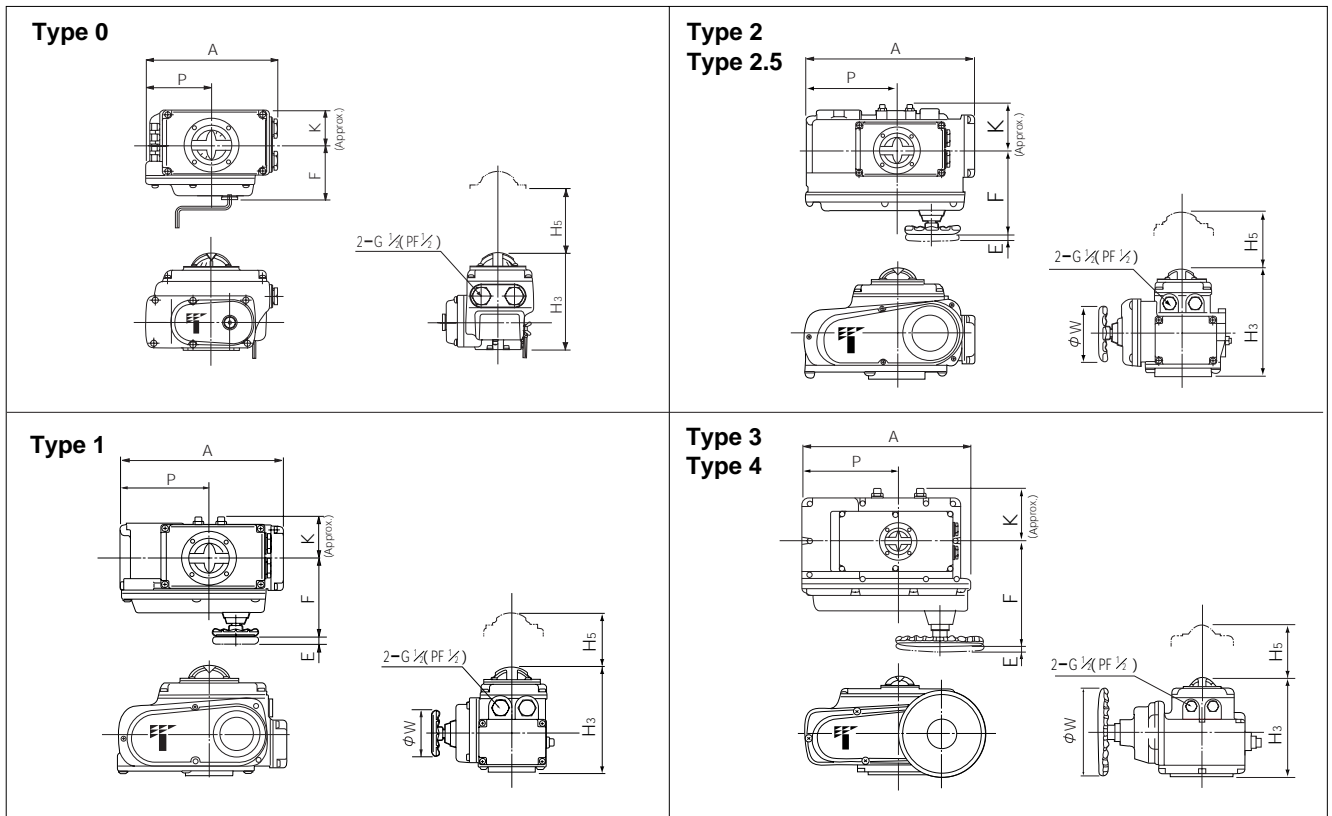

**New MICOM ELMY II Dimensions**

Motor type	Dimensions ( mm )								Approx. weight (kg)
	H3	H5	P	A	E	F	K	W	
Type 0	185	100	100	202	43	85	54	-	4.2
Type 1	191(193)	100	138	252	12	126	65	70	6.4
Type 2	224(227)	100	167	310	14	154	85	100	11.2
Type 2.5	224(227)	100	167	310	14	154	85	100	12.8
Type 3	255(258)	100	223	388	23	246	136	200	23.2
Type 4	255(258)	100	223	388	23	246	136	280	28.3

( ) shows non-ISO top dimension  
The figure in ( ) is for other than 700G.

- Actuator**
- New ELMY
- New MICOM ELMY II
- PMK-SRM
- SRJ
- LTKD
- T-DYNAMO
- TGA
- TG-S
- 3C
- Diaphragm
- Hydraulic type
- Manual type

## New MICOM ELMY II Wiring diagram

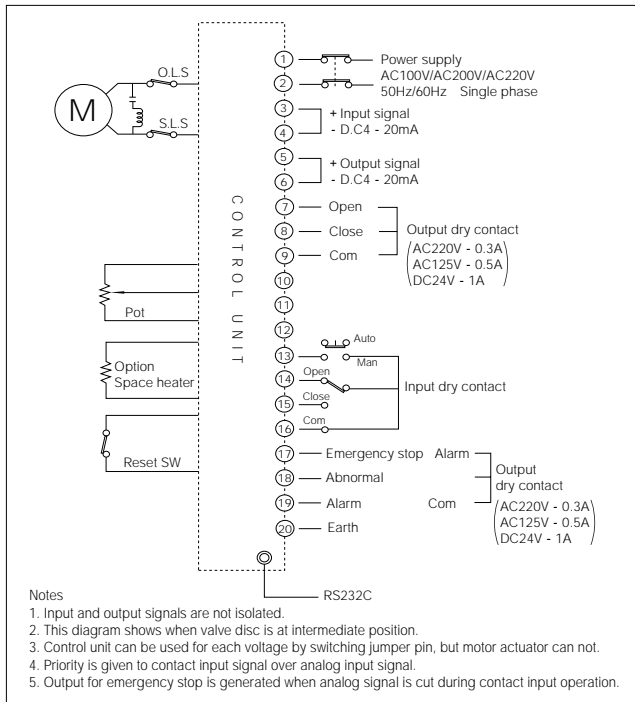

## New MICOM ELMY II Operation

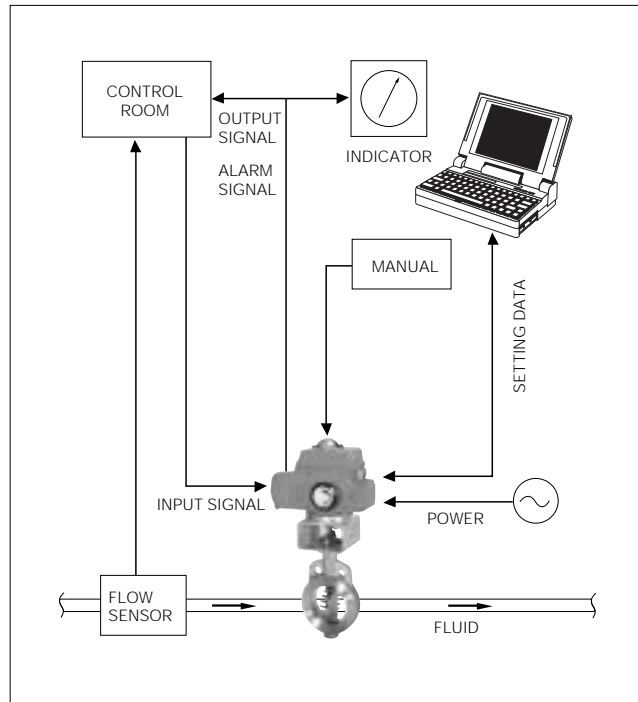

## New MICOM ELMY II Control functions

Function	By software	By DIP switch	Standard factory settings
Opening angle settings			0-90 or 0-70 degrees
Input signal settings			4-20mA
Output signal settings			4-20mA
Signal failure mode			Emergency stop
Signal failure mode variation		×	1mA or less is 5 sec.
Flow characteristic variation			Signal linear, CV linear for concentric type of valve, and CV linear for eccentric type of valve
Hysteresis variation		×	Input signal: 1.0% Angle signal: 0.5%
Hunting setting		×	Time for judgment: 180 sec Frequency of operation: 90 Operation angle range: 10 degrees Average angle: 5 degrees
Hunting interval setting		×	Signal hysteresis transition: 0.5% Interval limit hysteresis: 2% Automatically returns to hysteresis of time of shipping after 6 hrs.
High frequency operation		×	When signal hysteresis exceeds 2% for hunting interval
Abnormal output shaft operation		×	30 sec. × 3 times
Temperature monitoring		×	Alarm: 50 °C
Communication speed		×	9600bps
Logging data transmittal		×	
Display of setting data		×	

### Actuator

New ELMY

New MICOM ELMY II

PMK-SRM

SRJ

LTKD

T-DYNAMO

TGA

TG-S

3C

Diaphragm

Hydraulic type

Manual type

## New MICOM ELMY II Initial setting mode at the time of shipment

Input signal	Reverse action
Output signal	Reverse action
Flow rate adjustment	No adjustment
Action at the time of abnormal situation	Emergency stop
Flow adjustment data	Hold the data before reset
Setting mode entry	Operation mode

## New MICOM ELMY II Operating system

Usage environment	RS232C interface (Connector: D-sub 9-pin) PC that can run Windows 2000, ME or 98 (Please consult us regarding Windows XP support.) Connect to PC with dedicated cable.
-------------------	--

**New MICOM ELMY II Terminal board**

**Notes**

1. Input and output signals are not insulated.
2. Use FG terminal for earth.
3. Priority is given to contact input of terminal Nos. 14 to 16 over input signals of Nos. 3 and 4. Even terminal No. 13 is set to AUTO.

Terminal block screw size: M3 (with washer)

**Wiring diagram**

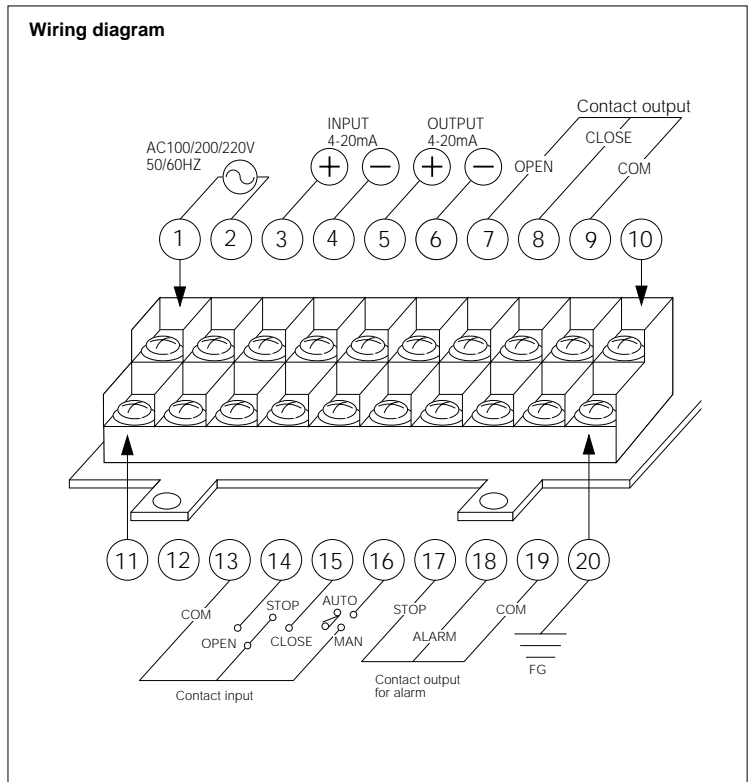

**New MICOM ELMY II Contacts**

**Terminals**

	Terminal No.	Purpose	Capacity
Contact output	No. 7 (OPEN)	Outputs at full open position	AC125V-0.5A DC24V-1A
	No. 8 (CLOSE)	Outputs at full closed position	
	No. 9 (COM)	COM for No. 7 and 8 terminals	
	No. 17 (STOP)	Outputs when abnormally stopped <sup>1</sup>	AC125V-0.5A DC24V-1A
	No. 18 (ALARM)	Outputs when alarm signal transmitted <sup>2</sup>	
	No. 19 (COM)	COM for No. 17 and 18 terminals	
Contact input	No. 13 (COM)	COM for No. 14, 15 and 16 terminals	
	No. 14 (OPEN)	Connect No. 13 when valve moves toward open direction	
	No. 15 (CLOSE)	Connect No. 13 when valve moves toward closed direction	
	No. 16 (AUTO/MAN)	Switching of auto and manual operation.	

<sup>1</sup>1: No. 17 works during signal failure, abnormal torque or temperature increase.  
<sup>2</sup>2: No. 18 works during hunting or abnormal temperature increase.

**Wiring diagram example for combination of auto and manual Operation by 4-20 mA signal. Closed during manual operation.**

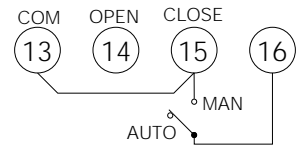

**Operation by 4-20 mA signal. Open during manual operation.**

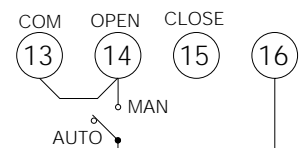

- Actuator**
- New ELMY
- New MICOM ELMY II
- PMK-SRM
- SRJ
- LTKD
- T-DYNAMO
- TGA
- TG-S
- 3C
- Diaphragm
- Hydraulic type
- Manual type

## New MICOM ELMY II Function and dip switch position

Setting item	Setting of dip switch							
	SW1	SW2	SW3	SW4	SW5	SW6	SW7	SW8
<b>Input signal</b>								
Reverse action	OFF						OFF	OFF
Direct action	ON						OFF	OFF
<b>Output (feedback) signal</b>								
Reverse action		OFF					OFF	OFF
Direct action		ON					OFF	OFF
<b>Opening degree adjustment</b>								
None(Linear in accordance with signal)			OFF	OFF			OFF	OFF
Cv linear for concentric valve			OFF	ON			OFF	OFF
Cv linear for eccentric valve			ON	OFF			OFF	OFF
For customer use			ON	ON			OFF	OFF
<b>Signal failure mode</b>								
Stop					OFF	OFF	OFF	OFF
Fully open					ON	OFF	OFF	OFF
Fully close					OFF	ON	OFF	OFF
Memorized opening degree					ON	ON	OFF	OFF
<b>*Initialization of setting data</b>								
Hold							OFF	OFF
Initialize							ON	OFF

### Notes

- Reset is necessary after switching.
- An asterisk means all setting data (such as valve opening degree, input signal, zero span of output single, etc.) will be initialized.
- Input signal: Reverse action: signal increase open  
Direct action: signal increase close
- Output signal: Reverse action: valve open signal increase  
Direct action: valve close signal increase
- Shaded areas mean initial setting mode at the time of shipment.

### Actuator

New ELMY
New MICOM ELMY II
PMK-SRM
SRJ
LTKD
T-DYNAMO
TGA
TG-S
3C
Diaphragm
Hydraulic type
Manual type

**New MICOM ELMY II Parts list**

**Types 0, 1, 2 and 2.5**

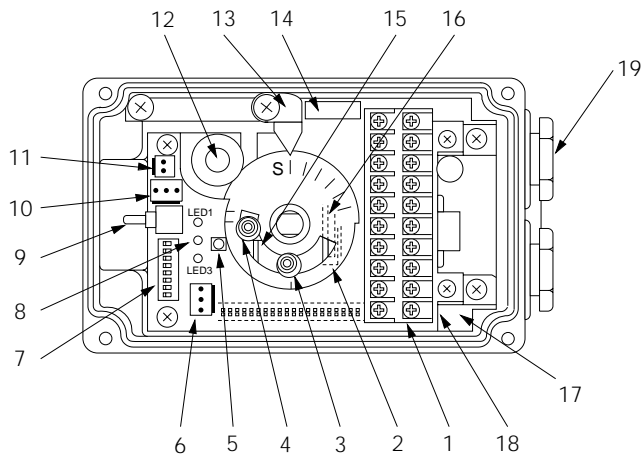

1	Terminal
2	Limit switch cam
3	Dog for open position
4	Dog for closed position
5	Reset switch
6	Connector for potentiometer
7	Dip switch
8	LED
9	Toggle switch
10	Connector for motor
11	Connector for motor capacitor
12	Potentiometer
13	Sub-indicator
14	Connector for interface
15	Limit switch (closed position)
16	Limit switch (open position)
17	Connector for heater
18	Jumper pin
19	Gland entry

**New MICOM ELMY II Parts list**

**Types 3 and 4**

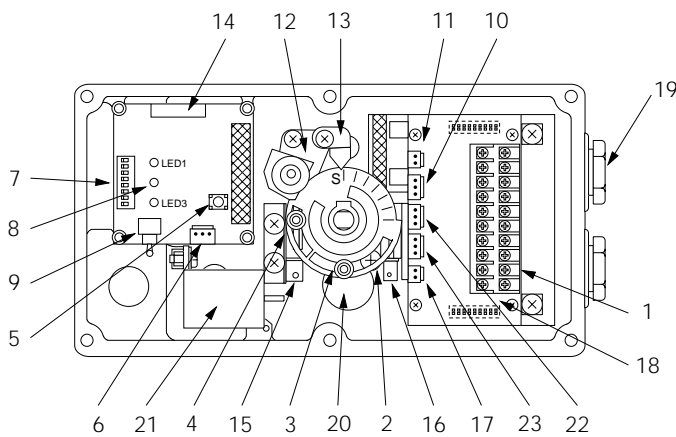

1	Terminal
2	Limit switch cam
3	Dog for open position
4	Dog for closed position
5	Reset switch
6	Connector for potentiometer
7	Dip switch
8	LED
9	Toggle switch
10	Connector for motor
11	Connector for motor capacitor
12	Potentiometer
13	Sub-indicator
14	Connector for interface
15	Limit switch (open position)
16	Limit switch (closed position)
17	Connector for heater
18	Jumper pin
19	Gland entry
20	Coil
21	Capacitor
22	Connector for open limit switch
23	Connector for closed limit switch

<b>Actuator</b>
New ELMY
New MICOM ELMY II
PMK-SRM
SRJ
LTKD
T-DYNAMO
TGA
TG-S
3C
Diaphragm
Hydraulic type
Manual type

### New MICOM ELMY II Recommended fuse and non-fuse breaker

Type	Power source and frequency	Recommended capacity for fuse	Recommended capacity for non-fuse breaker
0, 1	100V/110V ( 50Hz/60Hz )	3A	2.5A
	200V/220V ( 50Hz/60Hz )	2A	2A
2, 2.5	100V/110V ( 50Hz/60Hz )	5A	5A
	200V/220V ( 50Hz/60Hz )	3A	3A
3, 4	100V/110V ( 50Hz/60Hz )	10A	10A
	200V/220V ( 50Hz/60Hz )	7A	7A

#### Actuator

New ELMY

New MICOM ELMY II

PMK-SRM

SRJ

LTKD

T-DYNAMO

TGA

TG-S

3C

Diaphragm

Hydraulic type

Manual type