

Diaphragm

This type of actuator is used exclusively for rotary valves. The edge of the diaphragm is free, and by attaching a ring, the linear motion of the actuator is converted to a smooth rotational motion in the valve stem. Model 280 is a multiple spring type with four or six small internal springs, while Model 400 is a single spring type with one large spring. Both models are actuators that feature friction-free operation, excellent efficiency, and high output.

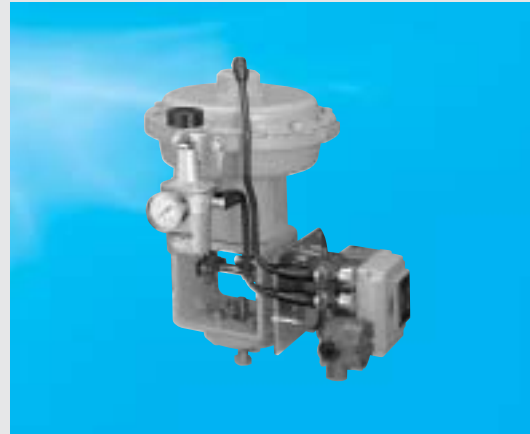

Diaphragm Specifications		
Type	280	400
Structure	Floating system	
Diaphragm area (cm ²)	350	725
Max. supply pressure (KPa)	270	
Spring range (KPa)	60 to 220(SUP.270)	60 to 190 (SUP.270)
Max. stroke (mm)	39.6	58.3
Applicable valve size (kg)	28.0 (Without top handle) (including bracket)	57.1 (Without top handle) (including bracket)

Remark: For both types 280 and 400, the manual handle (top handle) is available as an option.

Diaphragm Operation principle

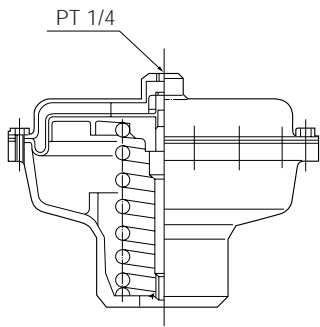

This type is exclusively used for rotary valves. The nose of the diaphragm is free, and by attaching a ring, linear motion of the actuator is smoothly converted to rotational motion of the valve stem. Type 280 is composed of four or six small springs, while Type 400 is a single spring type with one large spring. Both models feature friction-free operation, excellent efficiency, and high output.

Actuator

New ELMY

New MICOM ELMY II

PMK-SRM

SRJ

LTKD

T-DYNAMO

TGA

TG-S

3C

Diaphragm

Hydraulic type

Manual type