

227P

Butterfly Valves

TRITEC

TT2

334A

302A/303Q

304A/304Q

302Y/304Y

304M(HLV)

507V/508V

846T/847T/847Q

841T/842T

773Z(NAV-Z)

700G/704G/705G

731P/732P

732X/731X

700E/700K

704G/722F/720F

LRV

227P

MKT

903C/904C

A unique structure and low cost with proven reliability in water works, power generation, desalination plants and other industrial applications.

Unique seat ring

Unique seat ring structure provides low torque and long life. Grooves are molded on the sealing surface of the seat to reduce operating torque. An original retaining method is adopted. Plastic resin is injected from behind the seat ring to stiffen it. The resin-reinforced seat ring keeps constant compression through the entire disc to assure tight shut off.

Arch-shaped disc

A light weight and highly rigid arch-shaped disc allows fluid to pass through it when a valve opens. The valve opening area (Cv value) increases by approximately 15% compared to conventional designs. The pressure drop is also minimized.

Easy seat repair

Generally, the seat ring can be used for over 10 years without replacement. If any leakage is found, it can be easily repaired using an injection kit to inject resin into the seat ring surface at the point of leakage. The seat can also be replaced by a new seat with the injection kit.

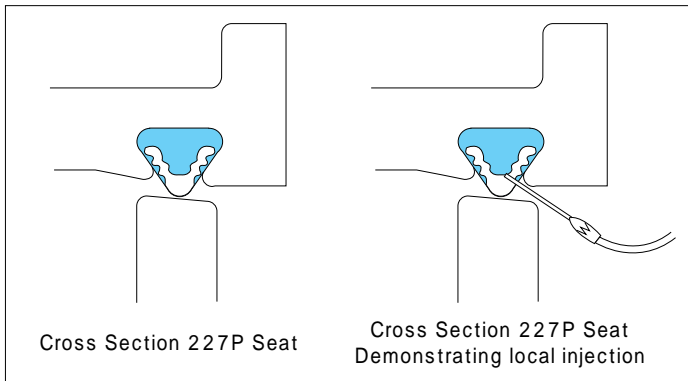
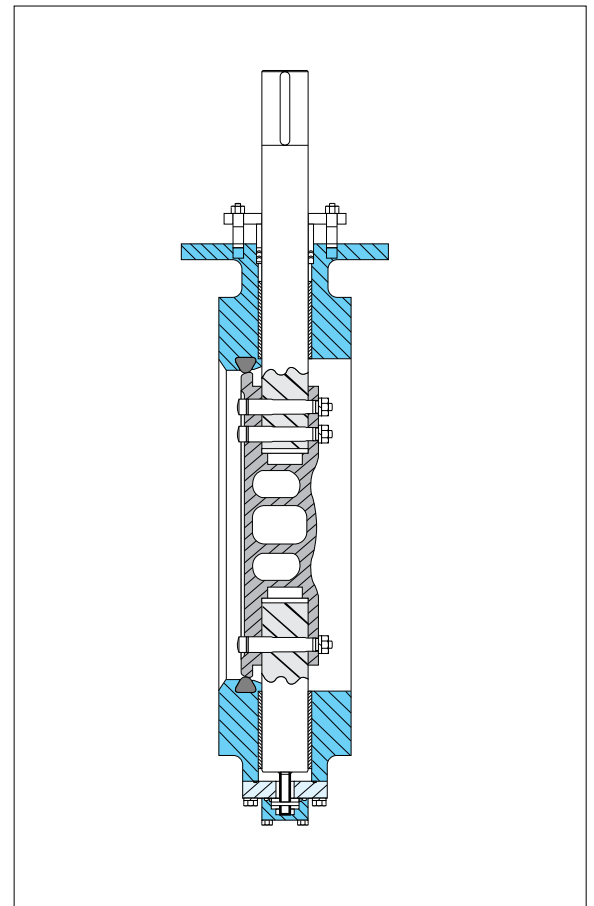
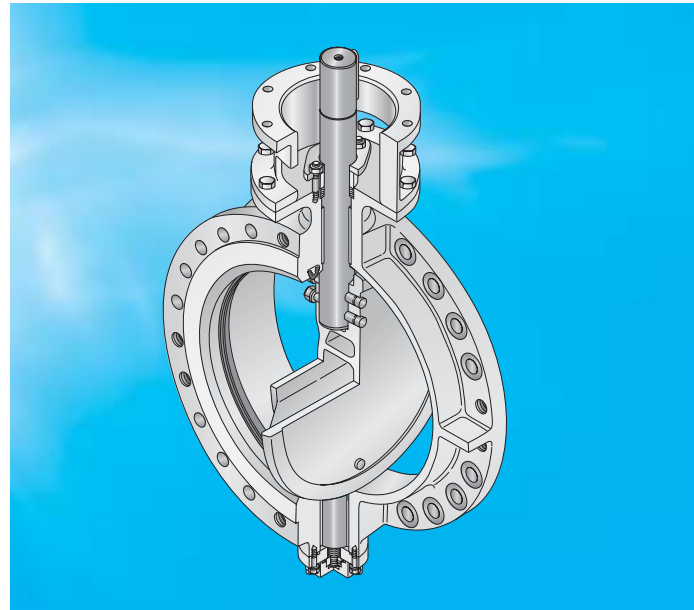

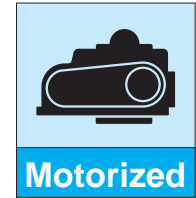
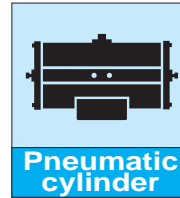
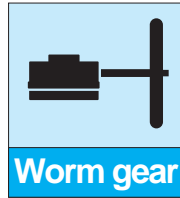

227P Standard specifications		
Valve nominal size	650mm to 2400mm	
Applicable flange standard	JIS 5K/10K, DIN NP10/NP16, JPI 150Lb, ANSI 125Lb/150Lb, AWWA	
Max. Working pressure	1.6MPa	
Pressure test	Body shell	2.4MPa (water pressure, max.)
	Seat leak	1.8MPa (max.)
Working temperature range	- 10 to 80 degrees C(NBR)	
Working temperature in continuous use ¹	0 to 60 degrees C(NBR)	
Standard materials	Body	FCD450, SCPH2
	Disc	SCS13, CAC702
	Stem	SUS304, SUS63, Monel K-500
	Seat ring	NBR, *EPDM
Special specification	Rubber lined body interior	
Coating	Primer (Munsell N7)	

Consult us with specifications if dimensions for actuator are required.

Actuators such as manual, pneumatic, electric and hydraulic ones can be selected upon adapt of detailed specifications.

1. "Working temperature in continuous use" stands for the temperature continuously kept exceeding one hour.

*No EPDM seat can be used for fluid containing any oil.

Butterfly Valves

- TRITEC
- TT2
- 334A
- 302A/303Q
- 304A/304Q
- 302Y/304Y
- 304M^(HLV)
- 507V/508V
- 846T/847T/847Q
- 841T/842T
- 773Z^(NAV-Z)
- 700G/704G/705G
- 731P/732P
732X/731X
- 700E/700K
- 704G/722F/720F
- LRV
- 227P**
- MKT
- 903C/904C

Large diameter / AWWA C504

Butterfly Valves

TRITEC

TT2

334A

302A/303Q

304A/304Q

302Y/304Y

304M(HLV)

507V/508V

846T/847T/847Q

841T/842T

773Z(NAV-Z)

700G/704G/705G

731P/732P

732X/731X

700E/700K

704G/722F/720F

LRV

227P

MKT

903C/904C

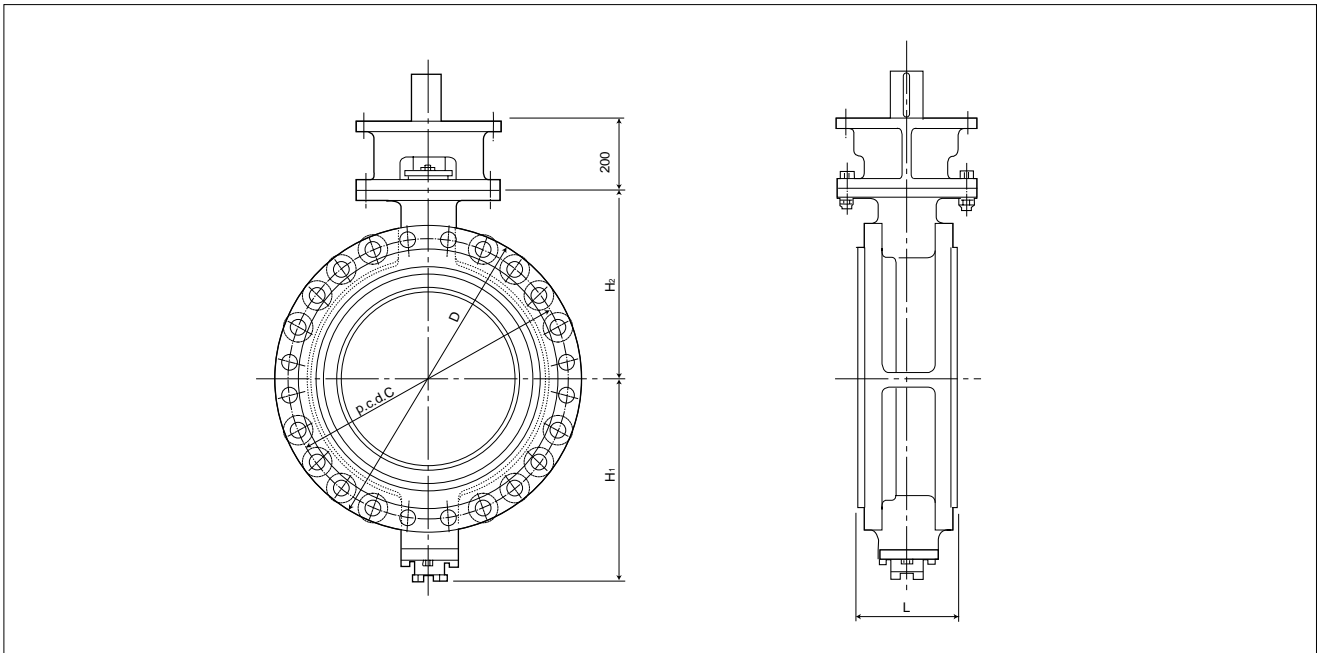

Dimensions

Nominal size		Dimension(mm)				
mm	inch	H ₂	H ₁	D	L	C
650	26	505	535	845	254	780
750	30	543	613	984	305	914
900	36	648	727	1168	305	1086
1050	42	737	815	1346	305	1257
1200	48	819	905	1511	381	1422
1350	54	905	991	1683	381	1594
1500	60	991	1108	1854	381	1759
1650	66	1092	1192	2032	457	1930
1800	72	1175	1299	2197	457	2096
1950	78	1320	1387	2362	457	2254
2100	84	1404	1514	2534	457	2426
2250	90	1495	1610	2705	533	2597
2400	96	1610	1715	2877	610	2756

Use the gasket size that complies with flange standard when installing.

Body flange thickness may not comply with the standard. Consult with us.

227P has two versions, AWWA type and general purpose type.

Maximum flow velocity range should be 6m/sec in full open position and 9m/sec during emergencies or for short durations without frequent opening and closing.

Technical data

227P 650-1,800mm (26-72 ") pressure classification
(Pipe inlet-pipe outlet)

25A, 25B - - - - -
75A, 75B —————
150A, 150B ··········

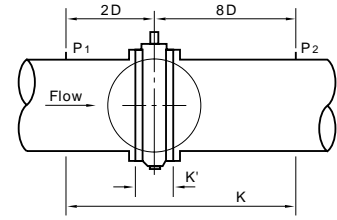

Flow coefficient based on K'

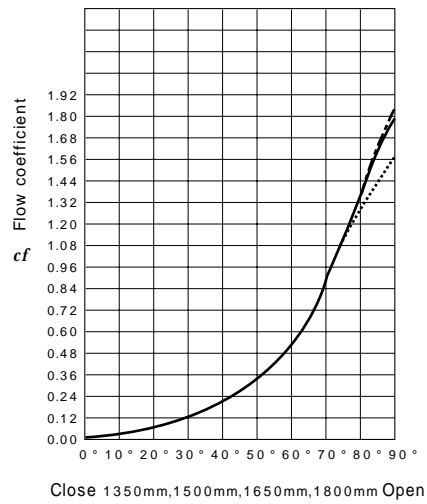
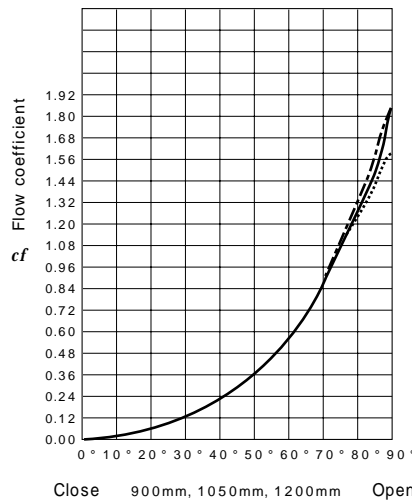
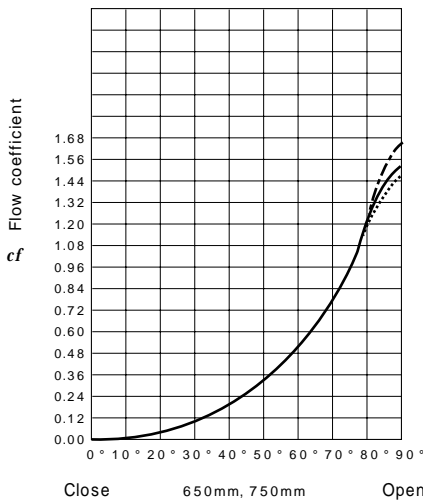

Flow coefficient based on K'

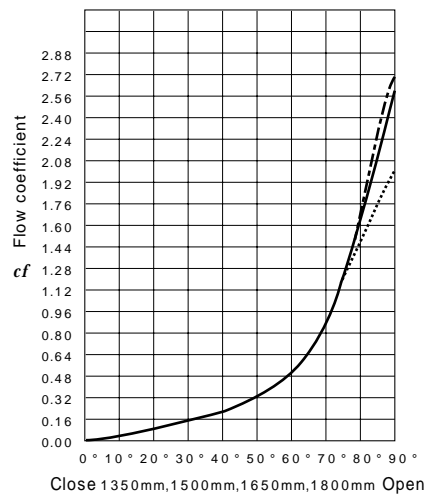
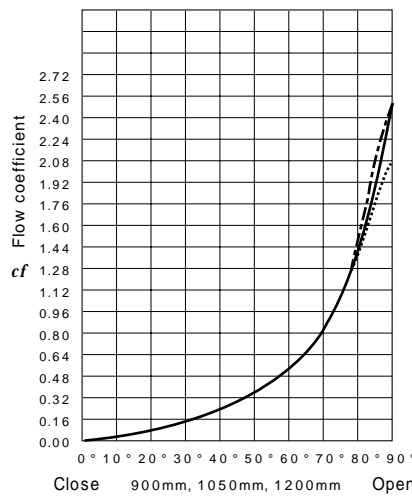
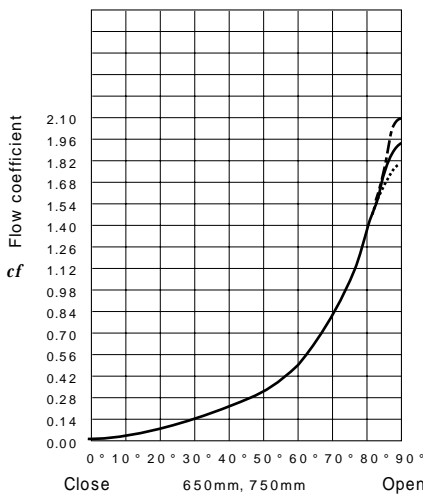

$$H = \frac{V^2}{cf^2 \cdot 2g}$$

H = Head loss (feet of water)
V = Flow velocity through piping (feet / sec.)
cf = Flow coefficient for piping, whose length is 10 times that of the pipe diameter, and that for valve
cf = Flow coefficient of valve only
g = 32.17 feet/sec².

Cv value:
 $Cv = 4294 \cdot cf \times D^2$ D: Internal diameter of pipe (feet)

Butterfly Valves

TRITEC
TT2
334A
302A/303Q
304A/304Q
302Y/304Y
304M(HLV)
507V/508V
846T/847T/847Q
841T/842T
773Z (NAV-Z)
700G/704G/705G
731P/732P 732X/731X
700E/700K
704G/722F/720F
LRV
227P
MKT
903C/904C